

TEST REPORT

Report number: 491 SATM10 – 0

**LOAD CAPACITY ON PROFILES - REF.: 38 x 40**

Load capacity of the profiles

The maximum loads are calculated according to the following conditions:

- The maximum bending is  $< L/150$
- The tests were done using a 200kN-capacity mechanical universal-testing machine

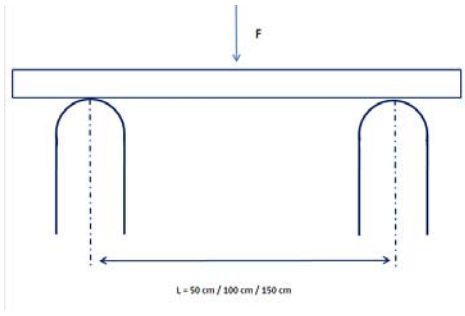
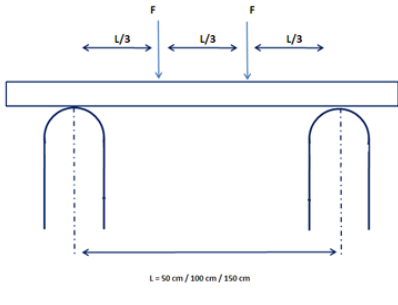
Profile Length (spam)	<p>3 points bending test</p> 	<p>4 points bending test</p> 
500 mm	<b>6624 N</b>	<b>8955 N</b>
1000 mm	<b>2498 N</b>	<b>3261 N</b>
1500 mm	<b>1170 N</b>	<b>1577 N</b>

General observations:

- Fundació Eurecat is not responsible for the validity of the additional information provided by the Customer (samples identification, technical documentation, etc.).
- The presented results refer exclusively to the material provided to the laboratory, as it is indicated in the corresponding paragraph, and tested under the conditions described in the norm/s and/or procedure/s mentioned in this document.
- Once the study is finished and in the case that the Customer doesn't claim for the provided samples, they will be eliminated in a period of time less than 6 months from the delivery date of the final technical report.
- It's not allowed the partial or total reproduction of this document without the written permission of the manager of Fundació Eurecat.

Manresa 11 - 11 - 2010



Carles Abad

Head of Technological services of Fundació Eurecat